



FDS 15 Product Information



The fine dust sensor FDS 15 is an optical sensor for continuous measurement and control of fine dust contents. It can be integrated into several applications.

Application

By means of the FDS 15 it is possible to determine the current fine dust loading of the environment and make out health hazards.

Application examples:

- monitoring of fine dust in the range of production (workshops, factory buildings etc.)
- monitoring of room air quality in offices and public institutions (hospitals, schools etc.) or in the private domain
- monitoring of ambient air
- upgrading of weather stations



Light path in the sensor housing

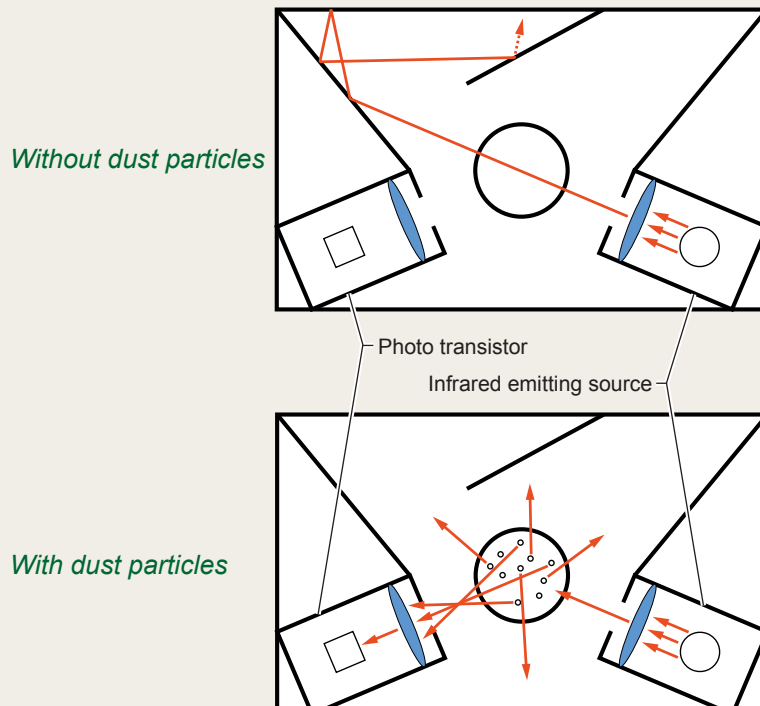

Function

The determination of the dust content in the FDS 15 is based on the method of scattered light measurement. The sucked air is pre-heated to 50 °C. Thereby flow enforcement takes place via the integrated fan (2 l/min). The velocity of the measuring gas is chosen in a way that particles are determined representatively.

In the FDS 15 a periodic control and correction of zero point and reference point is carried out. By evaluation of the internal measuring signals a high zero point stability is achieved.



Sensor design

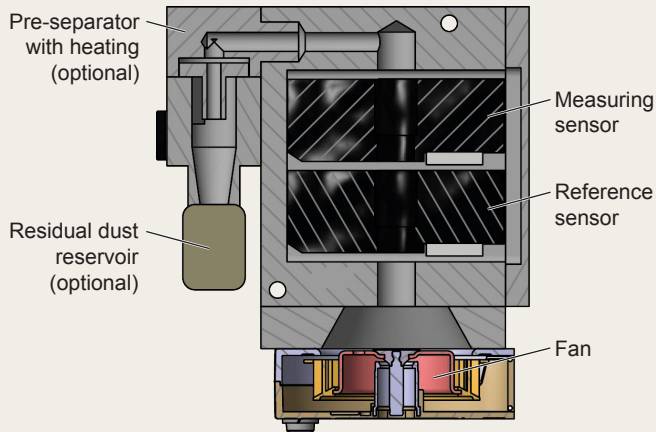

Highlights of the device

- robust design
- low-noise operation
- active suction
- long-term stability through two sensors
- cross linking of several FDS 15
- network-compatible, WLAN
- easy installation without special tool
- low operational costs
- first-class price-performance ratio

Technical data

Housing:	compact sensor housing made of aluminium
Dimensions:	130 mm x 160 mm x 90 mm (w x h x d)
Weight:	approx. 2 kg
Protection degree:	IP 33
Power supply:	100-240 V AC, 0.7 A, 50-60 Hz (optional 12-24 V DC, 2.1 A); pre-fuse min. 5 A
Ambient temperature:	-20...+50 °C
Relative humidity:	0...95%
Measuring method:	scattered light measurement → measurement of fine dust (PM _{2.5}) according to DIN EN 481
Sensors:	2x optical sensor; separated control and signal evaluation
Flow:	2 l/min
Interface:	RS485 (Modbus)
Clip contacts:	max. 0.5 mm; power supply connection: max. 2.5 mm
Fan:	for flow enforcement
Heating:	for conditioning of measuring gas (compliance with the dew-point spread)
Average dust contents:	up to 200 µg/m ³ (with electrostatic precipitator 500 µg)
Detection limit:	2 µg/m ³
Optional:	<ul style="list-style-type: none">- 4...20 mA current loop- WLAN module- pre-separator with regulated heating- electrostatic precipitator

Special models are possible on request.